

A NEW APPROACH FOR MEASURING LIGHT INSIDE THE CANOPY IN PHOTOSYNTHESIS STUDIES

PERTTI HARI¹, RAIMO SALMINEN², PAAVO PELKONEN¹, MIKKO HUHTAMAA² and VELI POHJONEN³

SELOSTE:

UUSI MAASTOKELPOINEN VALONMITTAUSMENETELMÄ YHTEYTTÄMIS-TUTKIMUKSIA VARTEN

Saapunut toimitukselle 1976-02-10

Light intensity inside the canopy varies considerably both in space and time. To avoid this difficulty, we have developed an apparatus which is disturbed as little as possible by the above-mentioned variation. The construction is based on the linear relationship between light intensity (measured using silicon diodes) and photosynthesis. This procedure permits linear operations (summing and integration) to be carried out on the output of the diodes without any loss of accuracy. There are five diodes in each assimilation chamber. Let $V_{ij}(t)$ denote the output of the j :th diode at the moment t , t_{1i} the beginning instant of the i :th photosynthesis measurement, and t_{2i} the moment when the i :th measurement is completed. Our equipment is constructed so that summing and integration takes place according to the following formula:

$$\int_{t_{1i}}^{t_{2i}} \sum_{j=1}^5 V_{ij}(t) dt.$$

A model, in which the independent variables include light, measured with the present equipment, and temperature, fits the photosynthetic rates well even inside the canopy.

INTRODUCTION

Although there are no serious technical problems involved in the monitoring of photosynthetic rate under field conditions, interpretation of the data obtained is rather complicated. This is due to the difficulties involved in measuring the light intensity. Light intensity, however, is the most important environmental factor affecting

¹) University of Helsinki, Department of Silviculture, Unioninkatu 40 B, SF-00170 Helsinki 17, Finland.

²) Helsinki University of Technology, Applied Electronics Lab. SF-02150 Espoo 15, Finland.

³) University of Helsinki, Department of Plant Husbandry, SF-00720 Helsinki 72, Finland.

photosynthesis in the humid conditions of the temperate zone (cf. NEUWIRTH 1963, SCHULZE 1970, 1972, EVANS 1973). The great temporal fluctuations in light intensity (cf. KORNHER & RODSKSER 1967, RODSKSER 1972, HARI & LUUKKANEN 1974), especially inside the canopy (cf. REIFSNYDER 1962, SETLIK 1968) make it difficult to obtain reliable measurements of the light intensity

which can be utilized in photosynthesis. The aim of the present paper is to describe some new equipment which we have designed for measuring light intensity in photosynthetic studies. The apparatus is not disturbed by the great temporal and spatial variations in light intensity inside the canopy.

THE EQUIPMENT

General setup of the field station

The light measuring equipment forms part of an automatic system for measuring gas exchange, growth and environmental factors in the field. Net photosynthesis and transpiration within the canopy and ground vegetation are monitored continuously during the growing season in a young stand of Scots pine (*Pinus silvestris* L.) with a few scattered Norway spruce at the University of Helsinki Forestry Field Station in Central Finland. The system includes two infrared gas analyzers (URAS, Hartmann & Broun AG, BRD) and 20 trap-type pneumatically operated assimilation chambers or cuvettes. One analyzer is used for monitoring CO₂ levels and the other for H₂O levels. The cuvettes are closed in a pre-arranged sequence for 100 seconds. The CO₂ concentration of the air in the cuvette is measured before the cuvette opens. Photosynthetic rate is determined on the basis of the difference between the CO₂ concentration inside and outside the cuvettes. A data-logging unit, supplied by Nokia Oy, Finland, is used to control the system and to collect the data for photosynthetic rate, transpiration rate, temperature and light.

the light intensity increases the output reaches a saturation level and the cell generates a constant voltage. The threshold value of the saturation level is greatly dependent on the value of resistance R_L . The relationship between the light intensity and the output of the photo cell is rather similar to the relationship between photosynthesis and the light intensity at constant temperature. Thus it is possible to construct a linear relationship between the photosynthetic rate and the output of the photo cell by including a suitable resistance in the circuit, which furthermore, makes it possible to construct a piece of equipment for measuring light intensity in photosynthetic studies. This apparatus is not disturbed by the great spatial and temporal variations in light intensity inside the canopy.

The equipment has been designed on the basis of the following mathematical analysis of photosynthesis. Let $P(t)$ denote the total amount of CO₂ fixed in photosynthesis at the moment t during the growing season. The photosynthetic rate f is defined as the time derivative of $P(t)$, thus

Requirements for a System to Measure Light Intensity

The output voltage of a photo-voltaic cell (Siemens BPY 11) is almost a linear function of the light intensity at low illumination in an electrical circuit as shown in Fig. 1 (cf. Optoelectronics semiconductors 1974). When

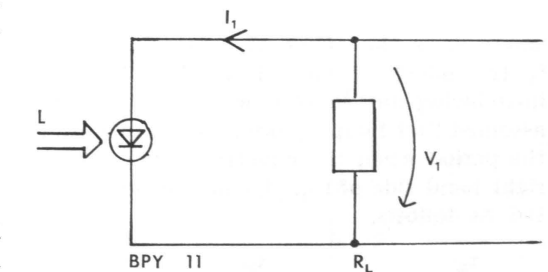

Fig. 1. The test circuit for the photo-voltaic cell BPY 11.

$$(1) \quad f = \frac{dP}{dt}$$

If there is sufficient water available in the soil for the plant, then the photosynthetic rate is determined primarily by the temperature x and by the light intensity y (cf. HARI & LUUKKANEN 1974) thus

$$(2) \quad f = f(x, y).$$

The photosynthetic rate is most frequently measured in the field by the so-called open measurement system. A living branch is placed in a chamber. The cuvette is closed for between 60 and 120 seconds before the CO_2 concentration in the cuvette is measured. It is then compared with the CO_2 concentration of the air outside. The cuvette is opened after the measurements have been made. Let t_{1i} be the moment at which the cuvette is closed for the i :th measurement and t_{2i} the moment when the cuvette is opened. When Eq. (1) is integrated from t_{1i} to t_{2i} , Eq. (3) is arrived at

$$(3) \quad \int_{t_{1i}}^{t_{2i}} \frac{dP}{dt} dt = \int_{t_{1i}}^{t_{2i}} f(x(t), y(t)) dt.$$

The left hand side of Eq. (3) represents the amount of CO_2 fixed in photosynthesis during the time when the cuvette was closed at the i :th measurement obtained directly with IRGA measurement. The right hand side of Eq. (3) can be simplified by supposing that the effect of temperature and light intensity on photosynthesis is multiplicative, *i.e.*

$$(4) \quad f(x, y) = f_1(x) f_2(y),$$

where f_1 is the effect of temperature and f_2 the effect of light intensity. Without introducing any large inaccuracy it can be assumed that temperature is constant during the period when the cuvette is closed. The right hand side of Eq. (3) can now be evaluated as follows.

$$(5) \quad \int_{t_{1i}}^{t_{2i}} f(x(t), y(t)) dt = \int_{t_{1i}}^{t_{2i}} f_1(x(t)) f_2(y(t)) dt$$

$$= f_1(x(t_{1i})) \int_{t_{1i}}^{t_{2i}} f_2(y(t)) dt.$$

There are great spatial fluctuations in light intensity in the cuvette caused by shading of the branches. The disturbing effect of shade can be to a great extent reduced by using several cells in the cuvette. If there is linear relationship between the output of the cells and photosynthetic rate at constant temperature, then there is no loss of accuracy in the linear operations, summing and integration.

The requirements put on the light measuring equipment discussed above can be summarised as follows:

1. There are n cells in a cuvette.
2. Let V_{1j} denote the output voltage of the cell j . The relationship between output V_{1j} and photosynthetic rate must be linear at constant temperature, *i.e.*

$$(6) \quad f(x, y) = a f_1(x) (V_{1j} y) + b, \text{ when } j = 1, 2, \dots, n.$$

3. The apparatus has to be able to compute the following integral (cf. KUBIN 1971).

$$(7) \quad V_{3i} = \int_{t_{1i}}^{t_{2i}} \sum_{j=1}^n V_{1j}(y(t)) dt.$$

The apparatus is built to simulate the dependence of photosynthesis on light. It takes into consideration the nonlinearity of this phenomenon (cf. Ross 1970). Changes in the spectral composition of light are considered as having little importance in field studies. The justification of the assumptions on which the equipment is based have to be tested with empirical data.

The construction of the equipment

A piece of equipment was constructed which fulfils the above requirements. We have called this apparatus, equipment for measuring light in photosynthetic studies (ELP). The block diagramme for the ELP

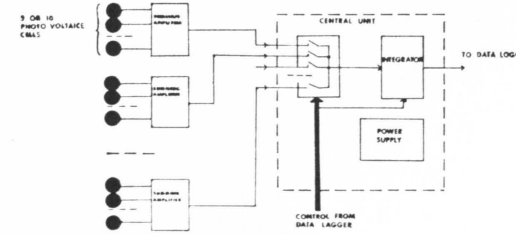

Fig. 2. The block diagramme of the ELP.

is shown in Fig. 2. According to requirement 1, there are n photo-voltaic cells in each cuvette, the output voltages of all the cells being summed together. The signal corresponding to light intensity which can be utilized in photosynthesis is transferred from the cuvette to the central unit (CU), consisting of an integrator and a multiplexer. The multiplexer selects which signal is to be passed to the integrator. The data logger reads the output of the integrator two seconds before the cuvette is opened. When the cuvette is opened and the next one is closed the integrator is reset and the multiplexer selects the signal from the cuvette which has just closed.

A photo-voltaic cell (Siemens BPY 11) was used as the light sensor. The electrical properties of the photo-voltaic cell are characterized by the following Eq. (cf. SZE, S.M. 1969).

$$(8) \quad V_1 = \frac{m k T}{q} \ln \left(\frac{I_1}{I_0} + 1 \right)$$

Where

- V_1 = the output voltage of the photo cell
- T = absolute temperature
- I_1 = photo current
- I_0 = constant
- m = constant
- k = Boltzmann constant
- q = Electronic charge

The photo current depends on the illumination and the load resistance R_L (c.f. Fig. 1). The relationship between V_1 and L is shown in Fig. 3. using the resistance values 1 $k\Omega$, 2 $k\Omega$, and 3 $k\Omega$.

The dependence of photosynthetic rate on light intensity in constant temperature

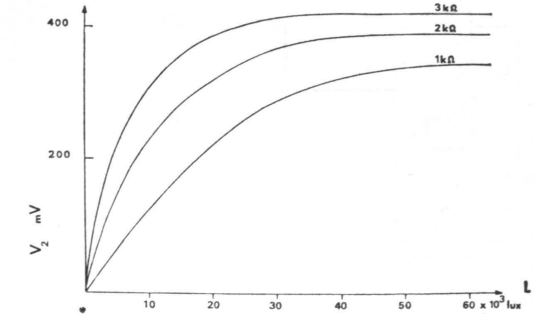

Fig. 3. The dependence of the output of the BPY 11 as function of illumination with both resistances 1 $k\Omega$, 2 $k\Omega$, 3 $k\Omega$.

is rather similar to the photo current — illumination relationship — of the photo cell by including a suitable resistance R_L in the circuit. This enables the dependence of photosynthetic rate on light intensity to be simulated by means of a photo cell.

Summing amplifier

The output signal of the photo cell is so low that it cannot be transferred more than a few meters. For this reason a summing amplifier is located near each cuvette. The circuit diagramme for amplifier is shown in Fig. 4. The output voltage of the circuit V_2 depends on resistances R_F and R_L and, on the input voltage V_1 as follows.

$$(9) \quad V_2 = - \frac{R_F}{R_L} V_1$$

The input resistance of the circuits is R_L . Thus R_L can be used as the load resistance of the photo cell. The desired

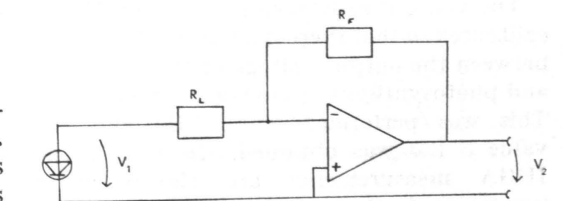

Fig. 4. The circuit diagramme of the inverting amplifier for one photovoltaic cell.

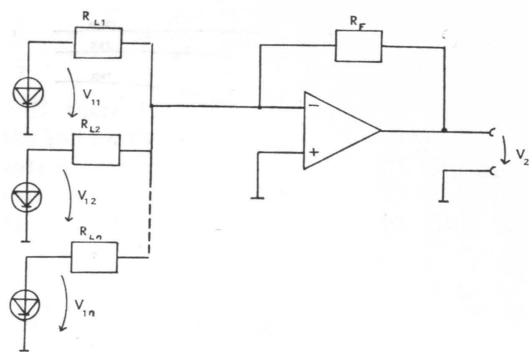

Fig. 5. The circuit diagram of the summing amplifier.

degree of nonlinearity of the relationship between photo current and illumination can be obtained by adjusting the resistance of R_L . The gain can be determined by varying the value of resistance R_F . The circuit can be expanded into a summing amplifier according to the circuit shown in Fig. 5. The output of the summing amplifier number l V_{2l} is

$$(10) \quad V_{2l} = - \sum_{j=1}^n \frac{R_F}{R_{Lj}} V_{1lj}$$

where V_{1j} is the output of photo cell number j and summing amplifier l and R_{Lj} is the load resistance of photo cell number j .

Central unit

The central unit consists of a 20 channel multiplexer, and an integrator. The mul-

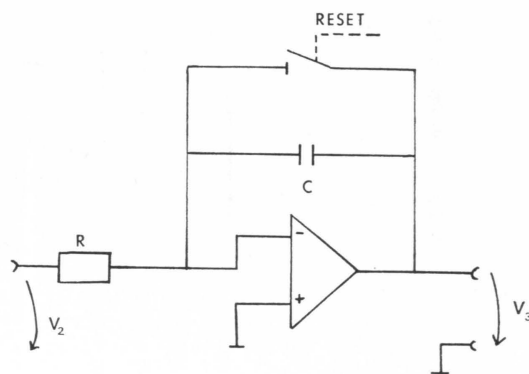

Fig. 6. Simplified diagram of the analog integrator.

tiplexer selects the signal to be integrated. The circuit diagram of the integrator is shown in Fig. 6. Let t_{1li} be the closing instant of the i^{th} measurement of the l^{th} cuvette and t_{2li} the opening instant, correspondingly and V_{2l} the output of the l^{th} summing amplifier and V_{3li} the output of the integrator in the i^{th} measurement of the l^{th} cuvette. The integrator computes the following integral

$$(11) \quad V_{3li} = \frac{1}{RC} \int_{t_{1li}}^{t_{2li}} V_{2l}(t) dt.$$

When Eqs (10) and (11) are combined, it can be seen that the output of ELP fulfills the earlier-mentioned requirements.

RESULTS

The value of resistance R_L (cf. Fig. 1) was calibrated so that there is a linear relationship between the output voltage of the photo cell and photosynthesis at constant temperature. This was performed empirically and the value $3 \text{ k}\Omega$ was obtained. In Fig. 7 the IRGA measurements are shown as a function of the output of ELP in the temperature range $10^\circ\text{--}15^\circ\text{C}$ during the period 1974-06-06-06-23. It is clearly

evident that the linear relationship between the IRGA measurements and the output of the ELP holds rather well.

The maximum output varies from one summing amplifier to another due to small differences in calibration. For this reason the output of each amplifier is normalized so that it has the value 100 in full sunlight during summertime.

Let p_{ii} denote the results of the i^{th}

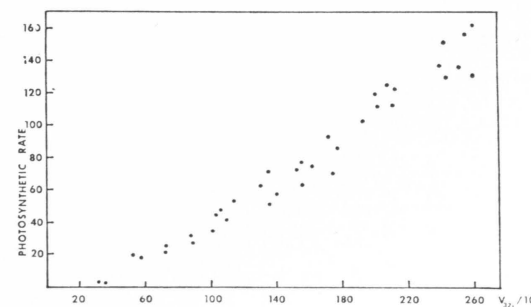

Fig. 7. The correlation between photosynthetic rate and the output of ELP in the temperature range $10^\circ\text{C--}15^\circ\text{C}$ during the period 1974-06-06-06-23.

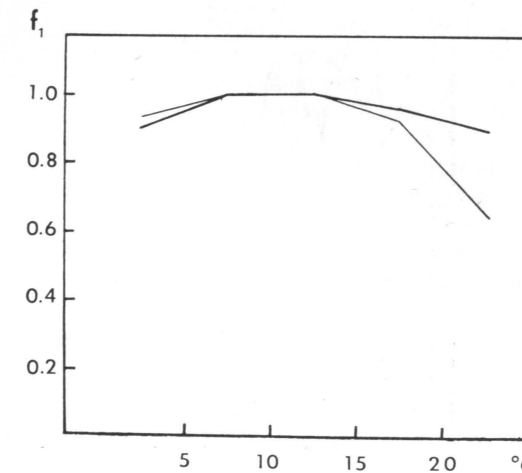

Fig. 8. The function f_1 for Scotch pine (thin line) and for Norway spruce (thick line).

IRGA measurement. of the l^{th} cuvette. When Eqs. (3), (6) and (7) are combined, the final model is obtained.

$$(12) \quad P_{ii} = a f_1(x(t_{1li})) (V_{3li}-b)$$

where f_1 is the effect of temperature, V_{3li} is the output of the ELP, and a and b are parameters which have to be estimated. The function f_1 and parameters a and b were determined separately for pine and spruce. The estimation was based on data collected during the period 1974-06-21-06-25 for Scots pine and during the period 1974-07-31-08-04 for Norway spruce. The

functions f_1 which were obtained are shown in Fig. 8. The measured photosynthetic rates and those computed from the model (Eq. (8) for pine during the days 1974-06-06, 06-07 and 06-10 are depicted in Fig. 9, and for Norway spruce during the period 1974-07-21-07-25 in Fig. 10. The model explained 86 % of the variance in photosynthetic rate for Scots pine and 89 % for Norway spruce during the periods shown in Figs.

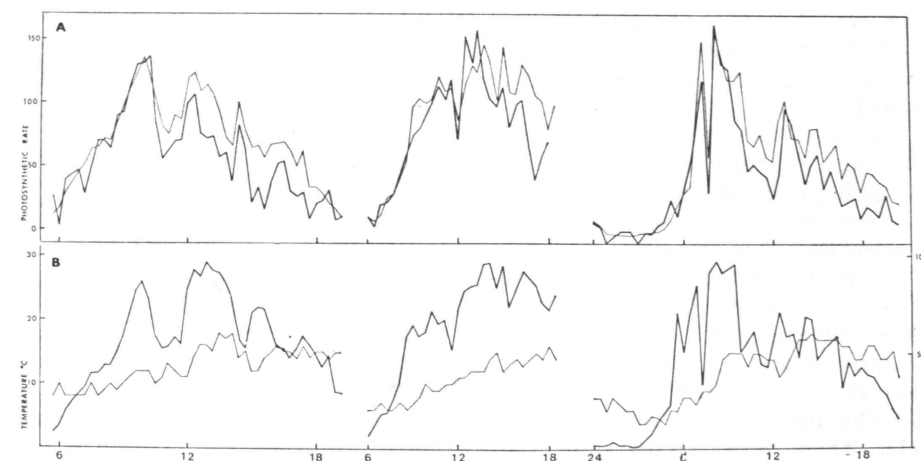

Fig. 9. A. Measured (thick line) and according Eq. (12) computed photosynthetic rates during the period 1974-06-06, 06-07 and 06-10 for Scotch pine.

B. The output of ELP (thick line) and temperature (thin line) during the period.

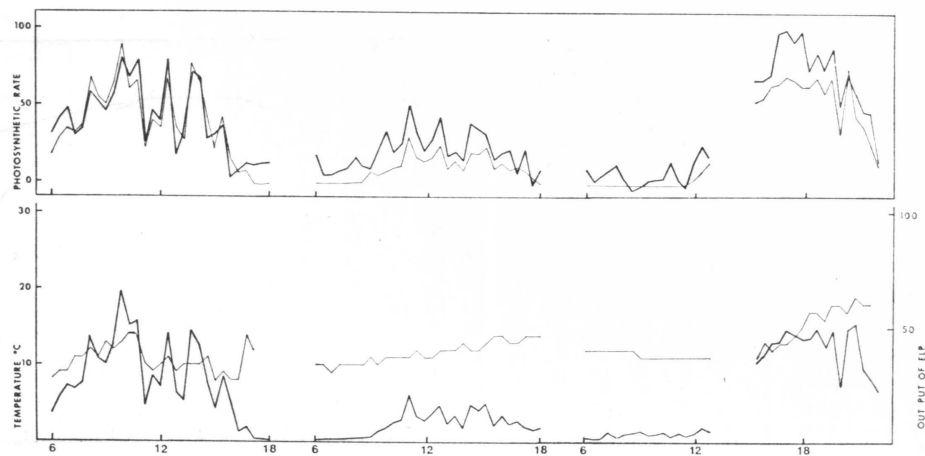

Fig. 10. A. As Fig. 9. A. but Norway spruce during the period 1974-07-21—07-25.

DISCUSSION

The temporal and spatial fluctuations in light intensity are very pronounced, especially inside the canopy. The moving shadows of branches bent by the wind cause sudden changes in the light intensity (cf. LOGAN and PETERSON 1964, HARI and LUUKKANEN 1974). The aim of the present study was to develop a system for measuring light intensity in photosynthetic studies. The apparatus is not likely to be disturbed by such fluctuations in light intensity. The design of the equipment was based on a mathematical analysis of the measurement technique for photosynthetic rate in a so-called open measurement system.

Since the ELP has to operate under field conditions, special care must be taken in the designing and implementation of the circuits. The components must operate reliably over the large temperature range (-10°C — $+40^{\circ}\text{C}$) and moist field conditions. The ELP proved, however, to work well under extreme field conditions even those of early winter.

The design of the ELP is essentially based on the properties of the photo cell (BPY 11). There seems to be some similarities between the characteristics of the photosynthetic rate and those of BPY 11, since otherwise such high correlations could not be obtained. The photo cell (BPY 11)

can be replaced by a linear photosensor but then much more complicated electronics or an on-line computer must be employed.

The piece of equipment was built to fulfill the requirements presented in Eqs. (6) and (7). The degree of accuracy of the measurements was satisfactory although it can be improved further. At the moment, measurement of the photosynthetic rate represents the weakest point in the system. Even this can be considerably improved by further developing the system. Attention must be paid to variations in the flow rate of air through the IRGA and to the degree of accuracy of the IRGA measurements.

Statistical analysis carried out on the data obtained showed, however, that the results were better than had been expected. The model (Eq. (8)) explained over 80 % of the variance in the photosynthetic rate in any of the computed periods in summer 1974. The measured and computed photosynthetic rates presented in Fig. 9 and 10 are merely examples to illustrate the fitness. In addition it must be kept in mind that the measured and computed photosynthetic rates are independent of each other, since the parameters in the model are estimated from data collected during the period 1974-06-21—06-25 for Scots pine and 1974-07-31—08-04 for Norway spruce.

Measurements of photosynthetic rate have been analysed rather superficially in the literature. There are only a few papers available, in which some statistical analysis has been performed (cf. REIFSNYDER, 1962). In particular, papers which consider photosynthesis inside the canopy are rare. This is most probably due to the great difficulties involved in measuring light intensity inside the canopy. Statistical analysis of photosynthetic rate is also rather complicated since the independent variables, temperature and light intensity, are strongly intercorrela-

ted and also because water deficit and temperature have a pronounced interaction in photosynthesis (HARI and LUUKKANEN 1973). Thus it is difficult to use standard statistical methods in the analysis.

The use of ELP and careful statistical analysis of the data make it possible to study photosynthesis in field conditions to an extent which has earlier only been possible in the laboratory. In this way, attention can be focused in the study on the ecologically important aspects of photosynthesis in the field.

LITERATURE

- EVANS, L. T. 1973. The effect of light on plant growth, development and yield. — In: Plant Response to Climatic Factors (ed. Slatyer, R. O.) Unesco, Paris.
- HARI, P. & LUUKKANEN, O. 1973. Effect of water stress, temperature, and light on photosynthesis in alder seedlings. *Physiol. Plant.* 29: 45—53.
- » — & LUUKKANEN, O. 1974. Field studies of photosynthesis as affected by water stress, temperature, and light in birch. *Physiol. Plant.* 32: 97—102.
- KORNHER, A. & RODSKJER, N. 1967. Über die Bestimmung des Globalstrahlung in Pflanzenbeständen. *Flora.* 157: 149—164.
- KUBIN, S. 1971. Measurement of radiant energy. — In: Plant Photosynthetic Production (ed. Sestak, Z. et al.) pp. 702—763.
- LOGAN, K. T. & PETERSON, E. B. A method of measuring and describing light patterns beneath the forest canopy. Department of forestry publication no. 1073: 1—26, 1964.
- NEUWIRTH, G. 1963. Die soziologische Bedingungen der Energienwertung durch Assimilation in Fichtenbeständen (*Picea abies* L.). *Archiv für Forswesen* 11: 1224—1240.
- Optoelectronics semiconductors. 1974. Siemens databook.
- REIFSNYDER, W. E. 1967. Forest Meteorology: The forest energy balance. — International review of forestry research, vol. 2, pp 127—179. New York—London.
- RODSKJER, N. 1972. Experimental investigations into the alternation of Solar radiation in field crops with special regard to the 0.3—0.7 mm spectral band. — *Wäxtodling Plant Husbanding* 27. Publications from the department of plant husbandry at the agricultural college of Sweden, 1972.
- ROSS, J. 1970. Mathematical models of photosynthesis in a plant stand. In: Prediction and measurement of photosynthetic productivity. Proceedings of the IBP/PP technical meeting, Trébon.
- SCHULZE, E-D, 1970. Der CO_2 — Gas wechsel der Buche (*Fagus silvatica* L.) in Abhängigkeit von den Klimafaktoren in Freiland. — *Flora.* 159: 177—232.
- » — 1972. Die Wirkung von Licht und Temperatur an den CO_2 — Gaswechsel verschiedener Lebenstformen aus der Krautschicht eines montanes Buchenwaldes. — *Oecologia* 9: 235—258.
- SETLIK, I. 1968. The use of integrating photoelectrical radiators recorders for the measurement of photosynthetically active radiation. — In: Functioning of Terrestrial Ecosystems at the Primary Production Level (ed. Eckardt, F. E.) Unesco, Liege.
- SZE, S. M. 1969. Physics of semiconductor devices Wiley — Interscience. New York.

SELOSTE:

UUSI MAASTOKELPOINEN VALONMITTAUSMENETELMÄ YHTEYTTÄMISTUTKIMUKSIA VARTEN

Nykyaikaisella mittausvälineistöllä voidaan kasvien fotosynteesiä seurata luotettavasti myös luonnon olosuhteissa. Maastomittauksissa kerätyn

aineiston analysointi on ollut kuitenkin hankalaa, koska mittausten aikana tapahtuvaa valon intensiteetin nopeaa vaihtelua ei ole pystytty rekisteröi-

mään fotosynteesitutkimusten kannalta luotettavasti. Varsinkin latvuston sisällä ja pilvisinä päivinä kerättyjen aineistojen analysointi on ollut epätarkkaa. Tässä tutkimuksessa esitellään laite, jolla voidaan mitata fotosynteesin kannalta käyttökelpoisen valon määrää. Laite on testattu luonnon olosuhteissa latvuston sisällä tehdyin mittauksin.

Tässä työssä käytetty mittaamenetelmä perustuu tutkittavan puun tai sen osan sulkemiseen sadaksi sekunniksi akryylimuovista valmistettuun saranoituun lieriöön eli mittauskvyvetiin, jonka pituus oli 30 cm ja läpimitta 15 cm. Fotosynteesinopeus mitattiin kyveti-ilman CO_2 -pitoisuuden alenemisena näytteenottoajan kuluessa. Kyvetin ollessa kiinni valon intensiteetti latvuston sisällä vaihteli voimakkaasti. Tämän vuoksi laite integroi fotodiodin synnyttämää sähkövirtaa fotosynteesimittauksen ajan. Valointegraalin ja fotosynteesimittauksen vertaaminen oli mahdollista, koska laitteen valoanturina käytetty piidiodi ja kasvin CO_2 -vaihto reagoivat valon intensiteetin vaihte-

luun samalla tavoin (vrt. kuva 3). Toisin sanoen fotosynteesimittauslaitteen ulostulojännitteen ja fotosynteesinopeuden välinen riippuvuus oli suoraviivainen (vrt. kuva 7).

Sen lisäksi, että valon intensiteetti vaihteli voimakkaasti fotosynteesimittauksen kestäessä, olivat valaistusolosuhteet mittauskvyvetin eri osissa erilaiset neulasten keskinäisestä varjostuksesta johtuen. Tämä vaihtelu otettiin huomioon sijoittamalla yhteen kyvetiin 5 tai 10 piidiodia. Laite summasi eri valoantureihin tulevan fotosynteesin kannalta käyttökelpoisen valon määrän.

Valonmittauslaitteen konstruoinnin perustana on ollut fotosynteesimittausten matemaattinen analysointi. Spektrijakauman mittaamiseen ei ole kiinnitetty huomiota, koska spektrin muuttumisella ei ole merkitystä tässä työssä käytetyn tutkimusotteen kannalta. Edellämainitun oletuksen oikeutus todettiin testaamalla laite luonnon olosuhteissa latvuston sisällä (kuvat 9 ja 10).