

Responses of Olfactory Receptor Neurons of the Large Pine Weevil to a Possible Deterrent Neutroil® and Two Other Chemicals

Matti Huotari, Mareena Jaskari, Erkki Annila and Vilho Lantto

Huotari, M., Jaskari, M., Annila, E. & Lantto, V. 2003. Responses of olfactory receptor neurons of the large pine weevil to a possible deterrent Neutroil® and two other chemicals. *Silva Fennica* 37(1): 149–156.

Electrophysiological responses of olfactory receptor neurons were measured from the antennal sensilla of large pine weevils (*Hylobius abietis* L.) at 1 s exposure to Neutroil®-hexane mixture odour as a possible deterrent chemical and, for comparison, to α -pinene, α -pinene-ethanol mixture, and ethanol odours, respectively. Neutroil® is a commercial chemical pulp-mill product which has been studied earlier as a deterrent for large pine weevils with preliminary feed tests. In addition, ethanol, hexane and clean carrier air responses were measured.

Odour pulses and clean air, as a zero reference value, were directed at a fixed insect antenna in order to induce olfactory responses. Simultaneous olfactory responses, i.e. *Hylobius* electroantennograms (EAG) and action potential responses, were recorded and these responses of *Hylobius* olfactory receptor neurons (ORN), such as action potential rates, silent periods and EAG responses, were analyzed for all simultaneous recordings.

The exposures to α -pinene, α -pinene-ethanol mixture, pure ethanol and hexane caused an increase of the action potential rate (up to 70 pulses per second) in the ORNs sensitive to these odours, while the Neutroil®-hexane mixture exposures caused either silent periods with a duration between 0.6 and 1.1 s for 1 s exposure pulses or they had no response at all in the ORNs sensitive to the other odours. Thus, the possible deterrence may be caused by inhibition of some pinene-alcohol ORNs.

Keywords olfactory receptor neuron, attractant, repellent, *Hylobius abietis*, action potential, silent period, electroantennogram

Authors' addresses *Huotari, Jaskari and Lantto*, University of Oulu, P.O. Box 4500, FIN-90014 University of Oulu, Finland; *Annila*, Finnish Forest Research Institute, P.O. Box 18, FIN-01301 Vantaa, Finland **E-mail** matti.huotari@oulu.fi

Received 5 July 2002 **Accepted** 12 December 2002

1 Introduction

Large pine weevil (*Hylobius abietis* L.) is a pest insect affecting coniferous trees like pine (*Pinus sylvestris*) seedlings. It is a serious pest insect for pine seedlings all over the Nordic countries, and also for forestry in Europe (Moore 2001). For instance, in Sweden its annual seedling damages are about 25–650 M euros and there is about 80% mortality for unprotected seedlings (Schlyter 2002). In Finland, however, there are no full-scale observations on the damages, but there are some local estimations on the damages of *Hylobius* (Kinnunen 1999). Because the use of current insecticides permethrin and deltamethrin will be totally forbidden in some EU areas after 2003 (Watson 1999, Viiri and Kytö 2001), a new repellent for the large pine weevil will be necessary. The olfactory receptor neurons (ORN) of the large pine weevil were tested electrophysiologically. In our report we introduce the test results of a possible repellent for the large pine weevil control, termed Neutroil®.

The large pine weevil finds pine seedlings by means of its sense of olfaction. Pine seedlings emit α -pinene and ethanol odours, and large pine weevils are guided by these odours to the seedlings (Annala 1982). The weevil antennae are rather long, with club-like distal segments. Morphologically there are three types of olfactory sensilla on the antennae (Mustaparta 1974), and electrophysiologically 30 different types of defined ORNs have been classified (Röstelin et al. 2000), but no gender differences have been observed with *Hylobius*. The pine weevil ORNs respond strongly to pine odours, so that the action potential rate increases from a spontaneous level of 0–10 pulses per second (pps) to 100 or even up to 150 pps (Mustaparta 1975). The ORNs of the large pine weevil have also been screened using single cell recordings with different plant and other volatiles via gas chromatographic columns and they have been classified electrophysiologically for different plant volatiles in many studies (Wibe and Mustaparta 1996, Wibe et al. 1996, 1997, 1998). In forestry, damages caused by the large pine weevil have been prevented by chemical means, and mechanical prevention has been used as well (Kinnunen 1999). Biological control has also been studied for the prevention of large

pine weevil damages (Leather et al. 1999).

The purpose of this communication is to describe some preliminary tests conducted with electrophysiological methods using the action potential rate and EAG recordings for olfactory response studies of the large pine weevil during exposure to Neutroil®. The aim was also to study effects of Neutroil® on large pine weevil ORNs, and also differences in ORNs responses between different provenances. Pine weevil antennae were exposed to odour chemicals typical for pine trees, such as α -pinene, ethanol, α -pinene-ethanol mixture, in addition to Neutroil®-hexane mixture, and hexane. Neutroil® is a commercial product from forest industry which is used as a component of printing inks and for rust preventatives and also for some other applications. Neutroil® has been studied also with preliminary feed tests as a possible pine weevil repellent to prevent their damage to pine seedlings (S. Lilja, Finnish Forest Research Institute, pers. comm.). It was found some repellent effects by Neutroil® on *Hylobius*. Electrophysiological tests exposing the large pine weevil to Neutroil® have not been reported previously in the literature.

2 Materials and Methods

2.1 Insects

The large pine weevils used here were collected during late nineties from pine trunks and seedlings in southern Finland (Tuusula near Helsinki with the location of 60°25'15"N and 25°01'49"E) and also from a timber mill environment in northern Finland (Haukipudas near Oulu with the location of 65°10'35"N and 25°21'15"E) and they were stored as short periods as possible (between one and two days) and fed with fresh pine shoots in a refrigerator at 7 °C. It was not possible to determine the gender with alive insects and, therefore, the gender of each insect was determined after exposure experiments on the killed insect by the author EA. The ages of the insects were not known because of the collection from nature. Eighty large pine weevil antennae were used.

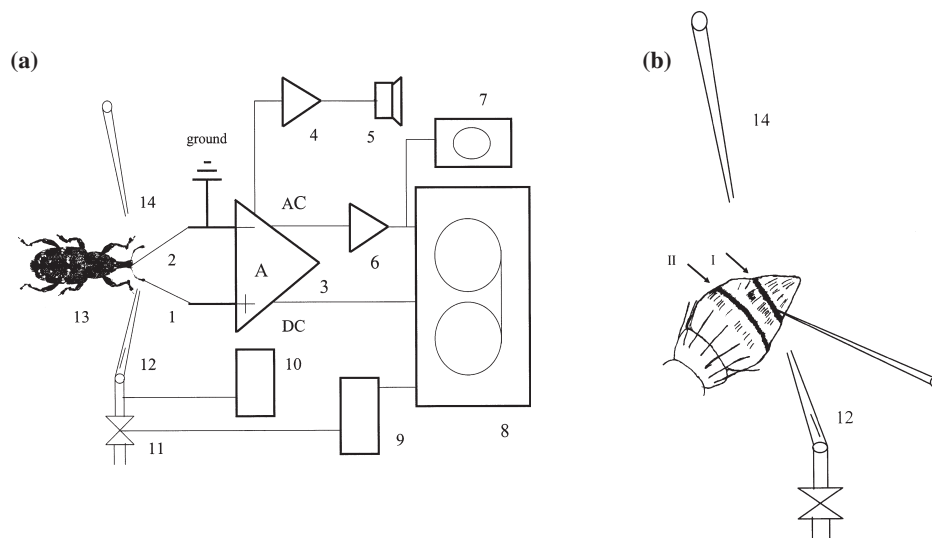

Fig. 1. (a) Schematic drawing of the odour exposure measurement system for large pine weevil ORNs. Recording (1) and reference (2) microelectrodes, microelectrode amplifier (3), audio amplifier (4), loud speaker (5), the instrument amplifier (6), oscilloscope (7), DAT recorder (8), electronic exposure control unit (9), rotameter (10), magnetic valve (11), filter paper in the Pasteur pipette (12), large pine weevil (13) and clean air flush flow (14). (b) Measurement areas (I, II) together with the recording microelectrode (I) at the distal area of the antenna club. The measurement areas are marked by I and II.

2.2 Electrophysiological Measurements

For the experiment a large pine weevil was put into a silicone rubber tube and one of its two antennae was immobilized with a metal hook. The microelectrodes used in the experiment were tungsten wires (0.5 mm diameter) etched to 1 μm tip diameter. The electrical contacts for recordings were at the proximal part of the antenna for the reference microelectrode and at an area between two distal segments for the recording microelectrode (Fig. 1a). The reference microelectrode was also connected to ground. The recording electrode was connected gently with a piezoelectric micro-manipulator (BURLEIGH 7010) to an olfactory sensillum in an area between two distal segments of the club (Fig. 1b). The sensilla contains one or two olfactory neurons (Mustaparta 1974).

Both the spontaneous and stimulated action potentials and the EAGs were amplified by a factor of 10 using a microelectrode amplifier (GRASS P16) (Fig. 1a). Fig. 1b shows a measurement installation where the recording

microelectrode is attached to the first area of the antenna. The two areas in the club where the recordings were made are also marked by I and II. The measured ORNs were also checked before the experiments to ensure that they were in good condition for the odour exposures. The action potential rate typically returned to its spontaneous level after the exposures ended.

In the measurement system the bandwidth was from 200 to 2000 Hz for action potentials and from 0 to 2000 Hz for EAG responses. The amplification factor was 20 for EAGs and 500 or 1000 for action potentials, which were amplified by an instrument amplifier (Tektronix A3026). The amplified action potentials were directed to an audio amplifier. Concurrently it was possible to listen to the action potentials with a loudspeaker. They were also monitored on an oscilloscope screen.

The amplified electrophysiological signals, time-marked together with 1 s odour pulses, were recorded on tape with a digital audio tape (DAT) recorder (TEAC RD-101T) with a resolu-

tion of 16 bits and a bandwidth between 0 and 11 kHz. The recordings were analyzed using a digital signal analyzer (HEWLETT PACKARD 35665A) and saved on floppy disk for documentation (Huotari 2000).

2.3 Odour Exposures

The olfactory responses were measured with microelectrodes from the ORNs in an antenna by alternating 1 s odour pulses with 60 to 120 s of clean air. The odour exposures and the clean air pulse were controlled by an electronic device connected with a magnetic valve (Fig. 1a). The exposures were directed at the fixed insect antenna to induce olfactory responses. The air flow at the exposure was monitored by a rotameter. (+)- α -pinene (98%, Merck), ethanol (99.5%, Alko Inc.), (+)- α -pinene-ethanol mixture (volume ratio 1:1) and Neutroil[®] (UPM-Kymmene Forestry Industry, Lappeenranta), which is a residue from a chemical pulp mill, were used as odour stimulants. Neutroil[®] was diluted in hexane (98%, Merck) using volume ratio 1:100 (1 ml Neutroil[®] was diluted to 99 ml hexane). Ten microlitres of each odour solution was transferred with a micropipette (Socorex) to the filter paper in the 3 ml Pasteur pipette. In the study, over 300 odour exposures were carried out with eighty large pine weevils.

In the actual measurements continuous clean air was also used to flush the odour chemicals away from the antenna during the intervals between the odour exposures. ORNs of eighty antennae were exposed to α -pinene, α -pinene-ethanol mixture and Neutroil[®]-hexane mixture pulses. For these tests, the ORNs which responded to these odours, but not to clean air, were chosen for further investigations. The odour exposure pulses were generated by clean air controlled by a magnetic valve in the pipeline and they were allowed to pass over the filter paper with an area of 1 cm² in the Pasteur pipette and were driven to the antenna (Fig. 1a).

2.4 Data Processing

The action potential rates during an exposure were calculated manually from graphical record-

ings and the observed average spontaneous action potential rate before the exposure was subtracted from the stimulated action potential rate. The number of stimulated action potentials was calculated over an interval of 500 ms in order to get an average action potential rate during that period (Huotari 2000). The silent period within the action potential train caused by odour exposure was determined as the time from the last action potential after the start of the odour exposure to the first action potential during or after the same exposure. This procedure was tedious to do manually. The EAGs were concurrently determined by the author MJ.

3 Results

The results are given in the form of graphs as a function of time showing both action potentials and simultaneous EAG response patterns. Figs. 2 and 3 show both the action potential and EAG responses of two ORNs and one ORN, respectively, at exposure to α -pinene odour pulses. In Fig. 2a the response is from two ORNs, and the action potentials from the first responding ORN are smaller in amplitude than those from the other ORN which started to respond a little later after the odour exposure. The action potential rate before and after the odour exposure was 2 pps, and the initial rate during the odour exposure 40 pps for the first, smaller amplitude ORN, and 10 pps for the latter ORN. The rates declined rapidly after the odour exposure was turned off. The corresponding EAG response is 5.5 mV as shown in Fig. 2b. The responses from the two ORNs overlap in the EAG response. The action potentials of the ORNs did not respond to the carrier clean air pulse alone.

Fig. 3 shows the two electrophysiological responses of an ORN identified according to the forms of the response patterns. No action potentials were observed before the α -pinene exposure, which caused a rate of 14 pps, as shown in Fig. 3a. The EAG response is 13.25 mV in Fig. 3b during the odour exposure and after the exposure the EAG signal started to return to the base line level.

The ORN in Fig. 4a responded to diluted

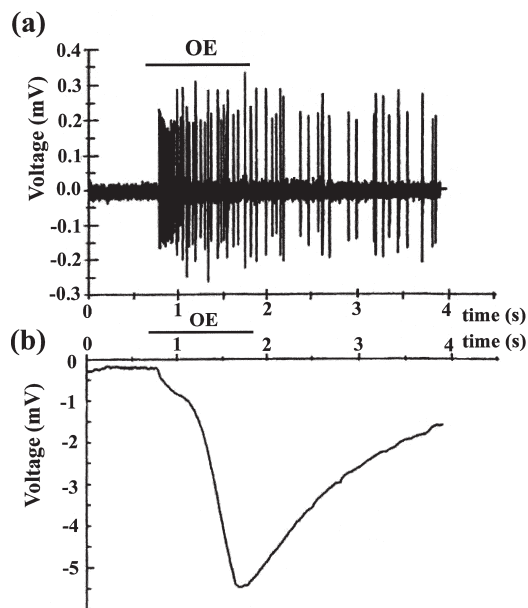

Fig. 2. (a) Action potential series of two pine weevil ORNs exposed to α -pinene and (b) simultaneous pine weevil EAG response of the same ORNs. The odour exposure (OE) is marked by a line in the upper part of both graphs.

Neutroil[®] odour exposure with a silent action potential period lasting 1.1 s, while before and after the odour exposure its spontaneous action potential rates were 14 pps and 13 pps, respectively. The corresponding EAG response is 0.22 mV (Fig. 4b).

Fig. 5a shows a response of the same ORN as in Fig. 4 at exposure to pure hexane odour. This exposure did not cause any changes in the production of action potentials in Fig. 5a. No EAG response was recorded (Fig. 5b), but action potentials are seen in Fig. 5a.

Fig. 6a shows a response of an ORN exposed to α -pinene-ethanol mixture odour. An increased action potential production begins immediately after the odour exposure reaches the antenna. This ORN was also exposed to pure ethanol odour, which caused an increase in the action potential production (Fig. 6b). The action potential response of the ORN at exposure to clean air is shown in Fig. 6c. The stimulated action potential responses to the two odour exposures were

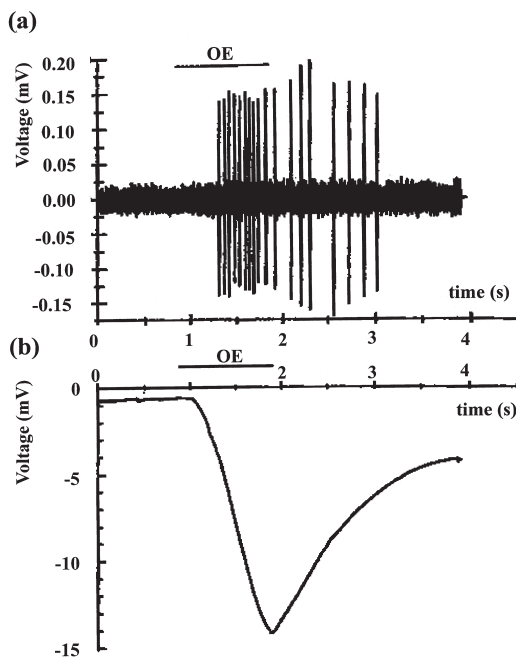

Fig. 3. (a) Action potential series of a pine weevil ORN exposed to α -pinene and (b) simultaneous EAG response of the same pine weevil ORN. The odour exposure is marked as in Fig. 2.

very similar, but no stimulated action potential response was seen to the clean air.

The simultaneous EAG responses at exposures in Figs. 6a, b and c are shown in Fig. 7, respectively. They are very similar to each other and it is impossible to distinguish differences in the responses between the two odour exposures (α -pinene and ethanol) and clean air.

The α -pinene, α -pinene-ethanol mixture and pure ethanol odour exposures all increased action potential rates in many different test measurements. Statistical average values, together with their standard deviations, were calculated from the test results to be $43.5 \pm (20-40)$ pps for action potential responses, and $0.95 \pm (0.25-0.3)$ s for silent periods. According to the results, α -pinene, α -pinene-ethanol mixture and pure ethanol odour exposures all generated average action potential rates between approx. 30 and 70 pps in the ORNs of both genders. The female values were, to some extent, higher than the male values in the case of the α -pinene-ethanol odour exposures. The

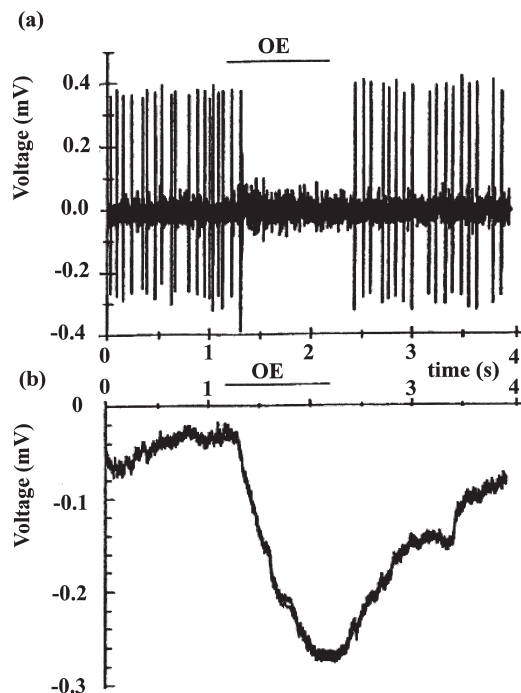

Fig. 4. (a) Silent period in the action potentials of a pine weevil ORN response exposed to diluted Neutroil® and (b) simultaneous EAG response of the same ORN. The odour exposure as in Fig. 2.

durations of the silent periods were between approx. 0.70 and 1.10 s for the diluted Neutroil® odour exposures. The average value of the silent periods and their standard deviations at exposure to diluted Neutroil® do not differ significantly between genders. It was not observed provenance differences in the response properties of the pine weevil ORNs collected from both northern and southern Finland on the basis of the odour responses recorded here.

4 Discussion

The olfactory responses of the large pine weevil to Neutroil® odour have not been tested earlier using electrophysiological methods. The response to diluted Neutroil® was very different from the response to other tested odours. Some large scale

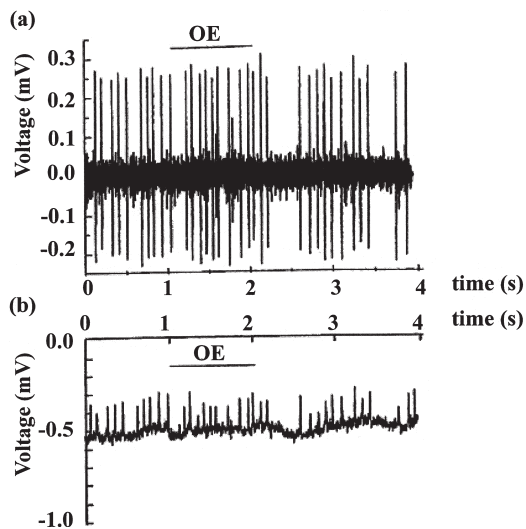

Fig. 5. (a) Action potential series of an ORN exposed to pure hexane and (b) simultaneous EAG response of the same ORN. The odour exposure as in Fig. 2.

tests against *Hylobius* are now under study on laboratory bred insects in Sweden (Schlyter 2002). These studies include also tests with Neutroil® mixture.

Typically, the ORNs of the pine weevil sent out action potentials randomly and the rate increased at exposure to α -pinene, ethanol or α -pinene-ethanol mixture, while the exposure to Neutroil®-hexane mixture odour typically caused a decrease of the rate or even a complete inhibition of the action potentials (silent periods). However, the inhibition is difficult to test on an electrophysiological basis on EAG responses (Vogler and Schild 1999). Neutroil® could be a potential candidate as a repellent mixture, if a proper supporting matrix can be found for it. Based on these preliminary tests it is not possible to draw other statistical conclusions than the average values and standard deviations. The tests were qualitative with respect to odour concentrations in the air and quantitative tests are strongly needed.

The attractiveness of the clearcut pine tree areas to the pine weevil was shown to be caused by monoterpene and ethanol odours originating from cut timber, stumps, twigs and slash (Annala 1982). In addition, it was shown that the odour of the

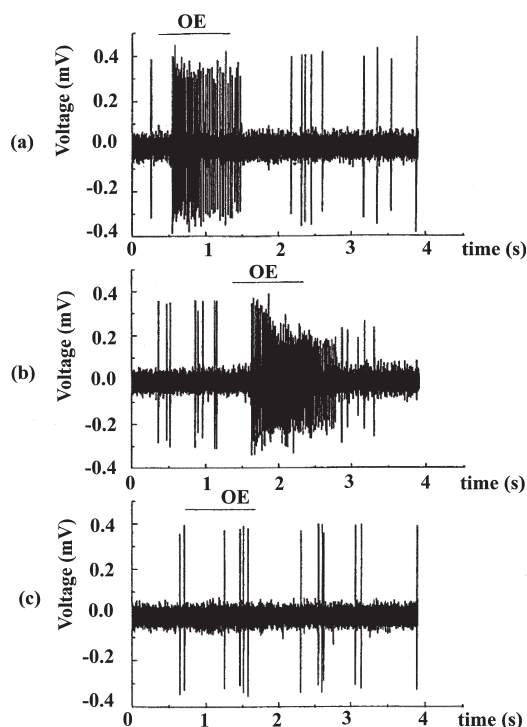

Fig. 6. (a) Action potential series of an ORN exposed to α -pinene-ethanol odour, (b) to pure ethanol odour and (c) to clean air. The odour exposures as in Fig. 2.

α -pinene-ethanol mixture was a more effective attractant than each of the odours alone.

The effects of attractant and repellent odours may be competing in different ORNs on a pine weevil antenna, and odour chemicals, such as α -pinene, α -pinene-ethanol mixture and ethanol presumably have an influence on the functions of pine weevil olfaction. Some other pest insects, e.g. some predators like *Trogossitta japonica* (Coleoptera: Trogossitidae) have also been shown to be attracted to α -pinene on the basis of EAG responses, as well as olfactometer tests (Nakamura et al. 1997, 1999, Nakashima et al. 1999).

In the present study diluted Neutroil[®] odour exposure caused a decrease or disappearance of the action potential rate in the same ORNs in which the α -pinene odour exposure increased the action potential rate on *Hylobius*. The

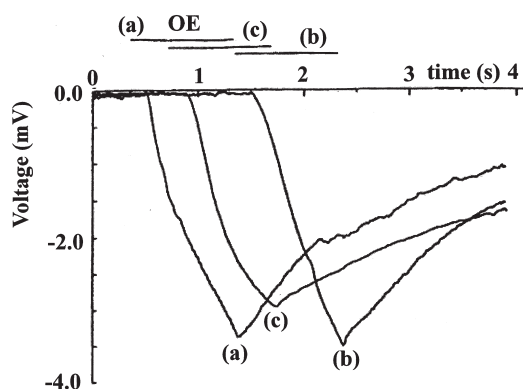

Fig. 7. Simultaneous EAG responses of the ORN to exposures shown in Fig. 6: (a) α -pinene-ethanol mixture odour, (b) pure ethanol odour and (c) clean carrier air. The odour exposures as in Fig. 2.

composition of Neutroil[®] is a complex mixture of numerous compounds with a wide range of molecular weights, as was shown in the two studies by Niemelä (1990) and Viljava and Brendenberg (1985). Neem oil based NeemAzal[®] (1% Azadirachtin A) may be a possible other repellent against *Hylobius*. Before large-scale field tests on repellents, it may be useful to have knowledge of their effects on the action potential response of the olfactory receptor neurons of a specific insect.

Acknowledgements

MH is grateful to the foundation Tauno Tönningin säätiö, to the UPM-Kymmene Forest Industry and to the Infotech Oulu Graduate School in Finland for financial support.

References

- Annala, E. 1982. Lindane treatment against *Hylobius* damage on paper pot seedlings of Scots pine. *Folia Forestalia* 512. 14 p.
- Huotari, M. 2000. Biosensing by insect olfactory receptor neurons. *Sensors and Actuators B* 71: 212–222.

- Kinnunen, K. 1999. Tukkimiehintäin tuhojen kemiallinen ja mekaaninen torjunta. *Metsätieteen aikakauskirja* 4/1999: 687–695. (In Finnish).
- Leather, S.R., Day, K.R. & Salisbury, A.N. 1999. The biology and ecology of the large pine weevil, *Hylobius abietis* (Coleoptera: Curculionidae): a problem of dispersal? *Bulletin of Entomological Research* 89: 3–16.
- Moore, R. 2001. Emergence trap developed to capture adult large pine weevil *Hylobius abietis* (Coleoptera: Curculionidae) and its parasite *Bracon hylobii* (Hymenoptera: Braconidae). *Bulletin of Entomological Research* 91: 109–116.
- Mustaparta, H. 1974. Response of the pine weevil, *Hylobius abietis* L. (Col.: Curculionidae), to bark beetle pheromones. *Journal of Comparative Physiology* 88: 395–398.
- 1975. Responses of single olfactory cells on the pine weevil *Hylobius abietis* L.. *Journal of Comparative Physiology* 97: 271–290.
- Nakamuta, K., Huotari, M., Usha, Rani P., Torkoro, M. & Nakashima, T. 1999. Olfactory responses of a predatory beetle *Trogossita japonica* to monoterpenes from the host tree of its prey. Abstract book of the Annual Meeting of the International Society of Chemical Ecology, ISCE, Nov. 13–17, Marseille, France. 90 p.
- , Leal, W.S., Nakashima, T., Tokoro, M., Ono, M. & Nakanishi, M. 1997. Increase of trap catches by a combination of male sex pheromones and floral attractant in longhorn beetle. *Journal of Chemical Ecology* 23(6): 1635–1640.
- Nakashima, T., Nakamuta, K., Huotari, M., Ueda, A., Fujita, K., Uurano, T. & Tokoro, M. 1999. Predatory beetle, *Trogossita japonica*, is attracted to volatiles from pine trees infested with prey insects. Abstract book of the 8th European Ecological Congress (EURECO'99), Sept. 18–23, Halkidiki, Greece. 107 p.
- Niemelä, K. 1990. Low-molecular-weight organic compounds in birch kraft black liquor. Dissertation in the Helsinki University of Technology, Helsinki, Finland. 142 p.
- Röstelin, T., Borg-Karlson, A.K. & Mustaparta, H. 2000. Selective receptor neurone responses to E- β -ocimene, β -myrcene, E,E- α -farnesene and homo-farnesene in the moth *Heliothis virescens*, identified by gas chromatography linked to electrophysiology. *Journal of Comparative Physiology A* 186: 833–847.
- Schlyter, F. 2002. Non-host volatiles and antifeedants from angiosperms directing host selection in conifer-infesting beetles from chemical ecology to forest protection. Pheromones and Other Semiochemicals in Integrated Production, Working Group Meeting, Sept. 22–27, Sicily, Italy. 49 p.
- Viiri, H. & Kytö, M. 2001. Tukkimiehintäituhot ja niiden torjunta. *Metsätieteen aikakauskirja* 2/2001: 270–274. (In Finnish).
- Viljava, T.R. & Brendenberg, J.B. 1985. Chemical modification and utilization of the neutral compounds in mixed birch-pine soap. *Paperi ja Puu* 12: 751–756.
- Vogler, C. & Schild, D. 1999. Inhibitory and excitatory responses of olfactory receptor neurons of *Xenopus Laevis* tadpoles to stimulation with amino acids. *Journal of Experimental Biology* 202: 997–1003.
- Watson, P.G. 1999. Influence of insecticide, wax and biofungicide treatments, applied to *Pinus sylvestris* and *Picea abies*, on the olfactory orientation of the large pine weevil, *Hylobius abietis* L. (Coleoptera: Curculionidae). *Agricultural and Forest Entomology* 1: 171–177.
- Wibe, A. & Mustaparta, H. 1996. Encoding of plant odours by receptor neurons in the pine weevil (*Hylobius abietis*) studied by linked gas chromatography-electrophysiology. *Journal of Comparative Physiology* 179: 331–344.
- , Borg-Karlson, A.K., Norin, T. & Mustaparta, H. 1996. Identification of plant volatiles activating the same receptor neurons in the pine weevil, *Hylobius abietis*. *Entomologia Experimentalis et Applicata* 80: 39–42.
- , Borg-Karlson, A.K., Norin, T. & Mustaparta, H. 1997. Identification of plant volatiles activating single receptor neurons in the pine weevil (*Hylobius abietis*). *Journal of Comparative Physiology* 180: 585–595.
- , Borg-Karlson, A.K., Persson, M., Norin, T. & Mustaparta, H. 1998. Enantiomeric composition of monoterpene hydrocarbons in some conifers and receptor neuron discrimination of α -pinene and limonene enantiomers in the pine weevil, *Hylobius abietis*. *Journal of Chemical Ecology* 24: 273–287.

Total of 21 references