

A field system for measuring the gas exchange of forest trees

Pertti Hari, Eeva Korpilahti, Toivo Pohja & Pentti K. Räsänen

TIIVISTELMÄ: METSÄPUIDEN KAASUJENVAIHDON MITTAUSJÄRJESTELMÄ

Hari, P., Korpilahti, E., Pohja, T. & Räsänen, P. 1990. A field system for measuring the gas exchange of forest trees. Tiivistelmä: Metsäpuiden kaasujenvaihdon mittausjärjestelmä. *Silva Fennica* 24(1):21–27.

The third generation of a forest tree gas exchange measuring system designed for the use in the field is described. The system is designed to produce data for determining the dependence of the rate of tree photosynthesis, respiration and transpiration on environmental factors. The system consists of eight cuvettes, a tubing system, two infrared gas analyzers, an air flow controller, a data logger, and a microcomputer. The measuring cuvette is a clap type, i.e. it is mostly open, only closing during measurement. CO₂ exchange is measured as the change in the cuvette concentration of CO₂, and transpiration is measured as the increase in water vapour concentration while the cuvette is closed. The environmental factors measured are: temperature, irradiance and air pressure. The system was planned in 1987 and constructed in 1988. It worked reliably in late summer 1988 and the quality of the data seems to be satisfactory.

Helsingin yliopiston metsäasemalle uusittiin metsäpuiden kaasujenvaihdon mittausjärjestelmä. Ekologisessa tutkimuksessa tarvitaan tietoa aineenvaihduntanopeuksien ympäristöriippuvuudesta. Mittausjärjestelmän suunnittelun lähtökohdaksi otettiin kaasuaineenvaihdunnan ja ympäristötekijöiden mittaaminen siten, että fotosynteesi- ja haihduntanopeuksien ympäristöriippuvuudet voidaan määrittää mahdollisimman tehokkaasti. Mittausjärjestelmässä on kahdeksan mittauskammiota, putkistot, kaksi infrapunakaasuanalysaattoria, kaasun virtausnopeuden säätäjä, datalokkeri ja mikrotietokone. Mittauskammiot sulkeutuvat mittauksen ajaksi. Pääosan aikaa ne ovat auki, jolloin kammion olosuhteet eivät poikkea kovinkaan paljoa ulkopuolisista olosuhteista. Hiilidioksidin vaihtoa ja haihduntaa mitataan kammioilman pitoisuuksien muutoksina. Lisäksi laitteisto mittaa valonvoimakkuutta, lämpötilaa sekä ilmanpainetta. Järjestelmä suunniteltiin 1987 ja rakennettiin 1988. Se toimi luotettavasti syksyllä 1988. Mittaustulosten laatu vaikuttaa tyydyttävältä.

Keywords: trials, monitoring, gas exchange, environment.
OCD 161

Authors' addresses: *Pertti Hari, Eeva Korpilahti and Pentti K. Räsänen*, Dept. of Silviculture, University of Helsinki, Unionink. 40 B, SF-00170 Helsinki, Finland. *Toivo Pohja*, Forestry Field Station, University of Helsinki, SF-35 500 Korkeakoski, Finland.

Accepted November 30, 1989

1. Introduction

Photosynthesis is the fundamental metabolic process of forests. Consequently, it is important to know the dependence of photosynthetic functions on environmental factors when trying to understand the functional basis of primary production. The inflow of carbon dioxide is always associated with an outflow of water vapour. Photosynthesis and transpiration are therefore closely linked together. It is all the more surprising that the monitoring of gas exchange is carried out at so very few locations. Portable measuring devices provide an opportunity to sample photosynthesis and transpiration of different leaves. This kind of data is, however, inefficient in determining the dependence of gas exchange on environmental factors.

A gas exchange monitoring system has been operating since 1972 during every growing season at the Forestry Field Station of the University of Helsinki. The first version of the measuring system was based on the use of a mechanical timing system, CO₂ analyser, irradiance and temperature sensors and chart recorders. The measuring system was under continuous development during the first years of its operation. The second version of the system was constructed during the years 1975–1978. The most important

improvement was the installation of a data logger to read the measurements and a microcomputer to store the results. The development of measuring techniques and the aging of devices during the eighties generated the need to reconstruct the system.

The measuring system played a key role in the field work of the Primary Production Research Group at the Department of Silviculture and at Forestry Field Station in Hyytiälä. It has contributed to twelve doctoral theses. The results have been reported in several papers (e.g. Hari and Luukkanen 1974, Hallman et al. 1978, Pelkonen 1980, Pelkonen and Hari 1980 and Hari et al. 1981). A summary of the results of the field measurements has been presented by Korpilahti (1988).

Helsinki University has offered the opportunity to reconstruct the gas exchange monitoring system in 1987–1988. The system was planned in 1987 and implemented in 1988. The main aim was to determine the dependence of photosynthetic functions on environmental factors. The construction is based on the experiences gained during the 15 years period of field work and on the efficient use of modern measuring techniques. The aim of the present paper is to describe the system constructed in 1988.

2. Theoretical background

Photosynthesis consumes carbon dioxide and produces oxygen. The measurement of photosynthesis can be based on both of these, but CO₂ provides the more suitable alternative, since the relative changes in its concentration are several orders larger than those of oxygen and accurate standard measuring devices are available. Consequently, the monitoring of photosynthesis is usually based on changes in CO₂ concentration. The measuring object has to be enclosed in a chamber or cuvette in order to obtain a large enough signal.

The CO₂ concentration in the cuvette is altered by the CO₂ exchanged by the plant and by the inflow of air into the cuvette replacing the gas needed for the gas analyser. Let C denote the CO₂ concentration in the cuvette, C_a the ambient CO₂ concentration, p the CO₂ exchange rate of the twig in the cuvette, q the inflow rate of air into the cuvette and V the volume of the cuvette. The combined effect of the CO₂ exchange and of the inflow of air is governed by the differential equation describing the cuvette CO₂ concentration.

$$V \frac{dC}{dt} = -p + q(C_a - C) \quad (1)$$

The measurement of CO₂ exchange can be made in three different ways, applying Eq. (1): i) an equilibrium method, ii) a difference method and iii) a dynamic method.

In the equilibrium method it is assumed that the cuvette CO₂ concentration is in equilibrium, then the time derivative of the cuvette concentration is zero

$$0 = -p + q(C_a - C) \quad (2)$$

Thus, the CO₂ exchange is compensated by the inflow of air into the cuvette. When this method is applied, it is assumed that photosynthesis is constant during a sufficiently long period. The time constant of the cuvette concentration is V/q . Usually, the time constant of the cuvette is of the order of one minute. This time is so long that the irradiance, and consequently the photosynthesis, may include considerable variation. The equilibrium assumption cannot be justified. However, this construction principle has been frequently used in laboratory measurements. The SWECON project applied the equilibrium method in the field (Persson 1980).

The difference method is based on the difference between the ambient concentration of CO₂ and its concentration in the cuvette. The amount of CO₂ exchange of the twig in the cuvette is obtained by integration from the moment of the closure of the cuvette, t_1 , to the moment of its opening, t_2 , i.e.

$$V(C(t_2) - C_a) = - \int_{t_1}^{t_2} p(t) dt + \int_{t_1}^{t_2} q(t)(C_a - c(t)) dt \quad (3)$$

The cuvette concentration is usually measured 50–100 seconds after the closing of the cuvette. For practical reasons, the

ambient and cuvette concentrations are measured consecutively. This is justified only if the ambient CO₂ concentration does not vary. This assumption fails during calm nights, which limits the applicability of the method. Our previous two versions of the measuring system are based on the difference method (Hari et al. 1979).

When the dynamic method is used, the concentration difference generated by the metabolism of the twig in the cuvette is measured. The interpretation of the result is based on the integration of Eq. (1) over the period from t_j to t_i as follows

$$V(C(t_i) - C(t_j)) = - \int_{t_j}^{t_i} p(t) dt + \int_{t_j}^{t_i} q(t)(C_a - c(t)) dt \quad (4)$$

Eq. (4) allows the measurement of the integral of photosynthetic rate over any period when the cuvette is closed. This generates problems in the interpretation of the measurements, but with proper arrangements for the measurement of environmental factors, the values of the parameters in models describing the dependence of photosynthesis on environmental factors can be estimated.

The cuvette CO₂ concentration is sampled at preset intervals, and when the dynamic method is applied, the number of measurements can be preselected. The number of measurements is large compared with the equilibrium and difference methods. This was a major disadvantage when analogue techniques were used in the construction. With the employment of a microcomputer the situation has changed. The dynamic method is not disturbed by rapid changes in environmental factors, nor by changes in the ambient concentration. The construction of The LI-6250 Gas Analyzer (LI-COR 1986) is based on the dynamic method.

3. The measuring system

The dynamic measuring principle was selected for the basis of the measuring system. The measuring system, constructed in 1988, consists of eight cuvettes, a tubing system for air flow, magnetic valves for selecting the cuvette to be measured, as well as for closing and opening of cuvettes, control system for air flow rate, two gas analyzers (CO_2 and H_2O), sensors for irradiance, temperature, and air pressure, a data logger and a microcomputer. The connections between the different parts of the system are outlined in Fig. 1.

The cuvette

The trap type cuvette, which is normally open, but closed for measurement, was selected, since its disturbing effect on the function of the measuring object is small and it suits well to the dynamic measuring principle (Fig. 2). There are several desired properties for the cuvette. These demands cannot be fulfilled simultaneously since, to some extent, they conflict with each other. The desired properties are:

1. The spatial variation of CO_2 concentration within the cuvette should be as small as possible.
2. When the cuvette is open, the leaves should have the same environmental conditions as neighbouring leaves outside the cuvette.
3. When closed, the cuvette should be as tight as possible, without any uncontrolled inflow of gas.
4. The cuvette should not change light conditions.

The requirements of gas tightness and of homogeneity of the CO_2 concentration were considered to be decisive.

In order to make the cuvette gastight, only the top of the cuvette and a hole in the lower part of the cuvette can open and close. A fan in the hole in the lower part can be adjusted to generate a constant air flow through the cuvette when it is open and to homogenize the CO_2 concentration inside the cuvette when closed for measurements. The cuvette is made of plexi glass and the amount of shade casting metal parts is minimized. The closing and opening of the cuvettes is arranged using

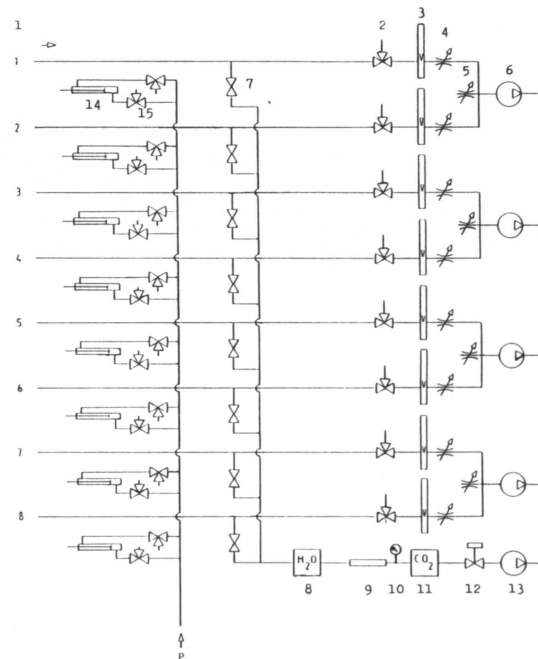

Fig. 1. Schematic presentation of the gas flow in the measuring system. c_1, c_2, \dots, c_8 cuvettes, 2 magnetic valve to select bypass flow, 3 flow meter, 4 and 5 controller of bypass flow rate, 6 and 13 air pumps, 7 magnetic valves to select the chamber for measurement, 8 IRGA for H_2O , 9 controller of water vapour, 10 pressure transducer, 11 IRGA for CO_2 , 12 flow rate controller, 14 pneumatic cylinders for opening and closing of cuvettes, 15 magnetic valves for operating of cuvette cylinders, and P pressurised air.

pneumatic cylinders and magnetic valves.

The cuvette is placed for measurement in such a way that the pine shoot to be measured is parallel to the axis of globe. The advantage of this arrangement is that the angle between the sun and the shoot does not vary during the day. The variation during growing season, say 1.5° – 23.9° , is also rather small, from 66° to 90° . Consequently, the mutual shading of needles in the shoot to be measured is as small as possible.

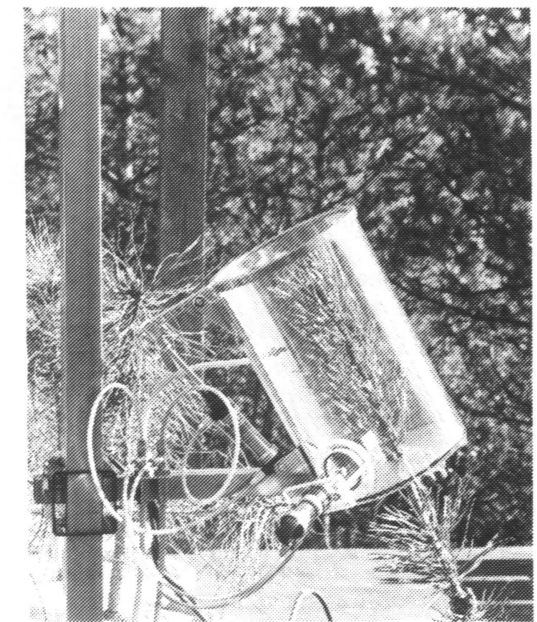
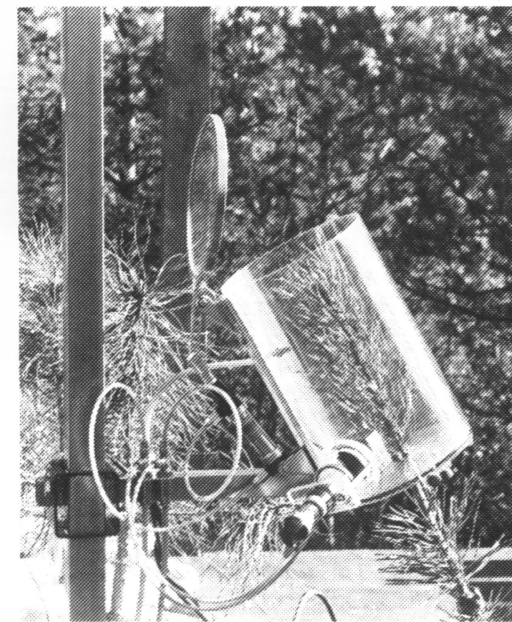

Fig. 2. The cuvette a. open and b. closed.

There is no artificial cooling system in the cuvette. The energy input caused by irradiance is transported from the cuvette by the air flow through the cuvette when the cuvette is open or consumed in transpiration. The velocity of air in the open cuvette is about 50 cm s^{-1} . This is nearly the wind speed within the canopy during calm days. During closure, the temperature in the cuvette is usually increasing due to energy input. The maximal increase rate is about 0.1°C s^{-1} , when the irradiance is high.

The tubing system

The tubing system was constructed of copper pipes (6 mm/4.4 mm), in order to avoid condensation and evaporation of CO_2 and water vapour on the surfaces of pipes. In addition, electrical warming of about 10°C was arranged to guarantee the undisturbed flow of water vapour through the system.

Flow rate control

The tubing system generates a time lag, about

20 s, between the concentration in the cuvette and the moment of its measurement. The concentration is changing rapidly in the cuvette, thus any variation in the flow rate of gas in the tubing system generates inaccuracies. This is why special emphasis was given to the control of flow rate.

The gas flow rate was measured and regulated by a mass flow controller (5850TR, Brooks Instrument B.V. Netherlands), which is able to maintain the preset flow rate within $\pm 1.5\%$ of the desired rate.

Sensors

The CO_2 and water vapour concentration is measured with an IRGA (URAS 3G, Hartmann & Braun, BRD). Temperature is monitored using copper konstantane thermopairs. Ambient air pressure and the air pressure difference between the IRGA and ambient air is monitored with pressure transducers (Schaevitz P 3061, Shaevitz Engineering, U.S.A.). A special system will be constructed for measuring irradiance. As a constant water vapour concentration is

required for the proper measurement of CO₂ concentration, the adjustment of water vapour concentration is performed by regulating the temperature of the gas to be measured to 1.0 °C.

Digital electronics and control of the system

The measuring system is controlled and the measured readings are stored by a microcomputer (Kontron IP286/W50, Kontron Mess-

4. Concluding remarks

The gas exchange measuring principle, whether equilibrium, difference or dynamic, determines the construction of a measuring system and the applicability of the measured results. It is clear that the dynamic principle is superior when using modern technology, since it is based on the least limiting assumptions and the interpretation of the results is straightforward. The large data set loses its importance as a limiting criteria when automatic data processing is used. The dynamic measuring principle has an additional advantage in that it allows the study of photosynthesis as a function of CO₂ concentration in field conditions.

The construction of an electric gas exchange measuring system to operate in field conditions includes special technical problems. The most crucial one is caused by water, either as condensation or rainfall, in electric devices or in the tubing system. Humidity in the electric devices may be fatal for the proper functioning of the circuits. Water in the tubing system destroys the transpiration measurements.

Lightning is able to generate sudden high voltage peaks due to electromagnetic induction. Special power and signal lines are required to minimize the risk of damage. Even in the case of careful protection, the risk of destruction remains. For this reason, the measuring system is switched off according to a well defined procedure when a thunderstorm is approaching.

The measured gas exchange results are integrals of photosynthetic, respiration and transpiration rate over cuvette volume and closing interval. On the other hand, photosynthesis is

technik GmbH, BRD). This type of computer is able to tolerate the demanding environment of field conditions. The measurements are carried by a data logger (Datataker DT100F, Data Electronics P/L, Australia).

Magnetic valves are employed for the closing and opening of the cuvettes. The microcomputer and data logger together carry out the proper timing of the opening and closing of the magnetic valves, as well as the selection of the cuvette for measurement.

responding to momental irradiance in the area of a stomata. This conflict in the scale of measurements and the basic phenomenon to be studied generates a need for special arrangements in the measurements of irradiance (cf. Hari et al. 1983). The construction of a new light measuring system will be finalized during spring 1989.

Portable measuring devices (LI-COR 1986) are the main instruments for field measurements of photosynthesis. The measuring approach is based on sampling the photosynthetic rate of various twigs. This kind of data is not efficient for determining the dependence of photosynthetic rate on environmental factors, since the rather large sampling error generates inaccuracies in the result. The monitoring of the same object for a prolonged period avoids the difficulty of sampling error. For this reason, permanent monitoring of the same object is superior when analysing the dependence of photosynthetic rate on environmental factors. Monitoring of the same object is not a common approach. However, monitoring the same object has a long tradition, i.e. since Polster 1955, which has been continued, for example, by Tranquillini 1966, Hari and Luukkanen 1973 and Persson 1980.

The system was constructed during the summer 1988 in a 25-year old pine stand 500 meters from the Forestry Field Station. The system worked reliably, although some minor problems arose in the connections between the different parts of the system.

References

- Hallman, E., Hari, P., Räsänen, P. & Smolander, H. 1978. The effect of planting shock on the transpiration, photosynthesis, and height increment of Scots pine. *Acta Forestalia Fennica* 161: 23 p.
- Hari, P., Kanninen, M., Kellomäki, S., Luukkanen, O., Pelkonen, P., Salminen, R. & Sievänen, R. 1979. An automatic system for measurements of gas exchange and environmental factors in a forest stand, with special reference to measuring principles. *Silva Fennica* 13(1):94–100.
- , Hallman, E., Salminen, R., & Vapaavuori, E. 1981. Evaluation of factors controlling net photosynthetic rate in Scots pine seedlings under field conditions without water stress. *Oecologia* 48:186–189.
- & Luukkanen, O. 1974. Field studies on photosynthesis as affected by water stress, temperature, and light in birch. *Physiologia Plantarum* 32:97–102.
- , Sievänen, R. & Salminen, R. 1983. On measuring in plant ecological studies. *Flora* 173:63–70.
- Korpilahti, E. 1988. Photosynthetic production of Scots pine in the natural environment. *Acta Forestalia Fennica* 202: 71 p.
- Pelkonen, P. 1980. The uptake of carbon dioxide in Scots pine during spring. *Flora* 169:389–404.
- & Hari, P. 1980. The dependence of the spring time recovery of CO₂ uptake in Scots pine on temperature and internal factors. *Flora* 167:257–264.
- Persson, T. (ed.) 1980. Structure and functioning of northern coniferous forests – An ecosystem study. *Ecological Bulletins* 32. Stockholm. 609 p.
- Polster, H. 1955. Die physiologischen Grundlagen der Stofferzeugung im Walde (Untersuchungen über Assimilation, Respiration und Transpiration unserer Hauptholzarten). *Archiv für Forstwesen* 4: 689.
- LI-COR. 1986. LI-6200 Technical Manual. Lincoln.
- Tranquillini, W. 1969. Das Klimahaus auf dem Patscherkofel im Rahmen der forstlichen Forschung. 2. Symposium für industrielle Pflanzenbau. Wien. p. 147–154.
- Total of 12 references*